

EMT-900-H

Magnetic Dimmable

Outdoor Stainless Steel Enclosure

Multi Tap: **12-15VAC**

Total Wattage: **900W max**

Input Voltage: **120V 60Hz**



www.emcod.com



Conforms to UL STD. 1838
Certified to CSA
STD. C22.2 No 250.0, 250.7

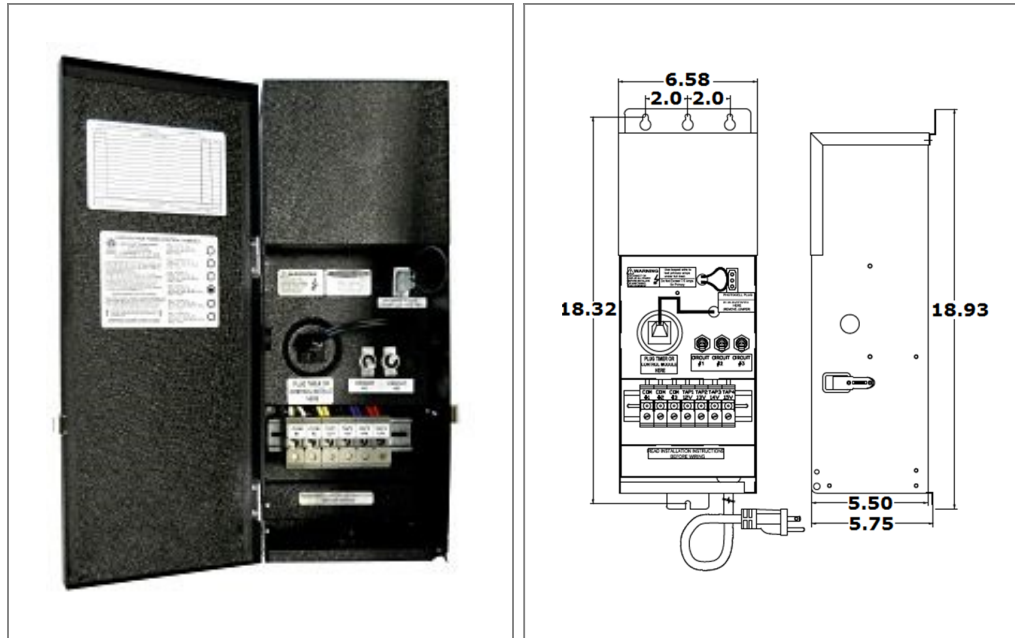

Transformer

Dimmable with any LV magnetic dimmer as long as you cover dimmer's min load.

Temperature class B(130°C)

Input leads: Line cord

Output leads: Terminal Block

Magnetic manually reset secondary breaker 25A per circuit

Timer and photocell build in options

Housing

The actual transformer 900W is encapsulated in the enclosure

The enclosure is Stainless Steel, NEMA 3R rated

Wiring compartment has 6 knockouts sizes for 3/8 inch screw cable connectors

Enclosure Temperature does not exceed 75°C at 45°C ambient and fully loaded

Dimensions (inch): H = 18.93, W = 6.58, D = 5.75

Weight (LBs): 35

Electrical Parameters

Input Voltage: **120V 60Hz**

Max. input current at full load: **7.5A**

Output voltage without load: **12/ 13.4/ 14.2/ 15.3VAC**

Output voltage fully loaded: **11.4/ 12.6/ 13.6/ 14.6VAC**

Max. Total Wattage: **900W** Max. per circuit: **300W**

Max. Output Current: **25/ 23/ 21/ 20A** per circuit.

Efficiency: **94%**

Load regulation: **4%**

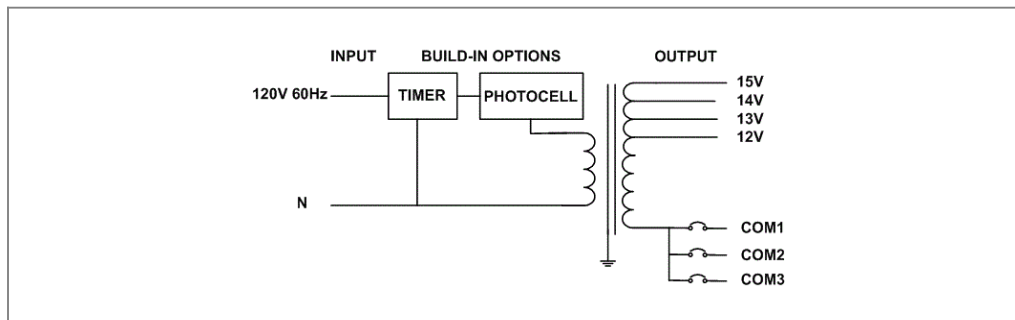

Mailing Address: 15545 Cabrito Rd. Van Nuys, CA 91406 Tech support: Arik Nirenberg phone: 818-904-3309 cellphone: 818-269-4091

Fax: 818 904 3327 info@emcod.com techsupport@emcod.com