

# ESL100W

## Magnetic Dimmable

Outdoor Stainless Steel Enclosure

Multi Tap: **12VAC and 15VAC**

Total Wattage: **100W max**

Input Voltage: **120V 60Hz**



Conforms to UL STD. 1838  
Certified to CSA  
STD. C22.2 No 250.0, 250.7

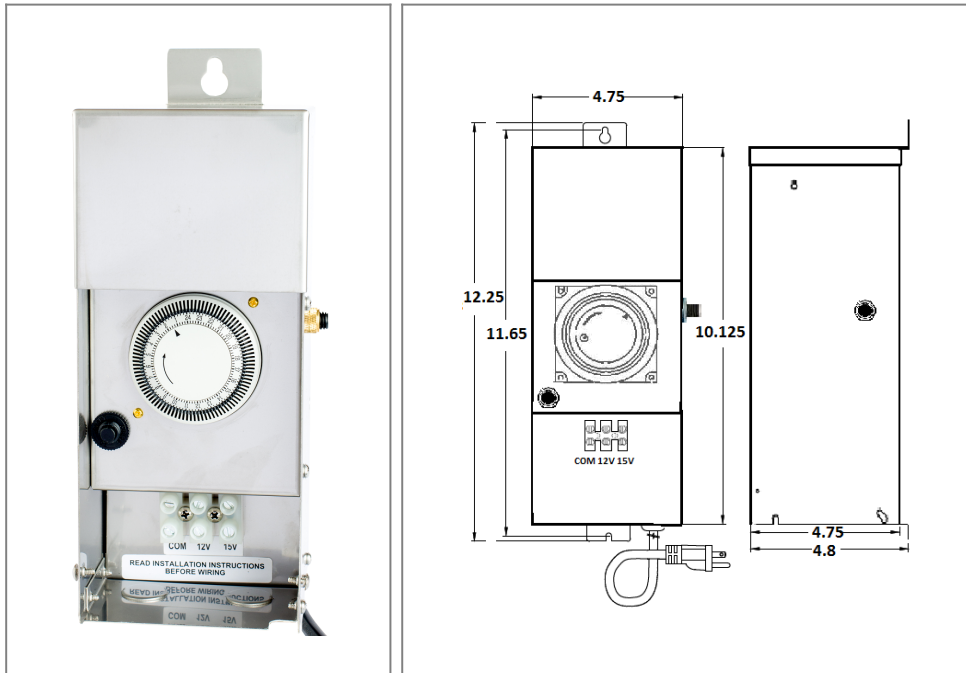

### Transformer

Dimmable with any MLV, CL dimmer, as long as, dimmer's min. load is covered.

Temperature class B(130°C)

Thermal manually reset secondary breaker 15A

Timer and photocell build in options

### Housing

The actual transformer 100W is encapsulated in the enclosure

The enclosure is Stainless Steel, NEMA 3R rated

Wiring compartment has 2 knockouts sizes for 3/8 inch screw cable connectors

Enclosure Temperature does not exceed 65°C at 45°C ambient and fully loaded

Dimensions (inch): H = 12.25, W = 4.75, D = 4.8

Weight (LBS): 9

### Electrical Parameters

Input Voltage: **120V 60Hz**

Max. input current at full load: **1A**

Output voltage without load: **12/ 15VAC**

Output voltage fully loaded: **11.5/ 14.5VAC**

Max. Total Wattage: **100W**

Max. Output Current: **8.3/ 6.6A**

Efficiency: **90%**

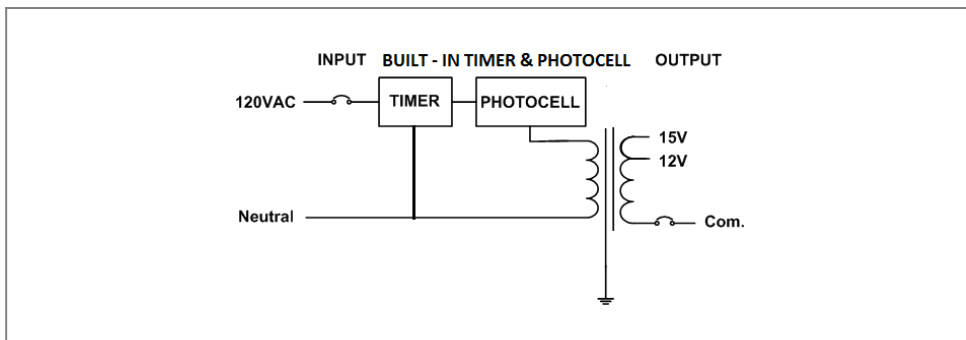

Mailing Address: 6925 Eton Ave. Canoga Park, CA 91303 Tech support: Arik Nirenberg phone: 818-904-3309 cellphone: 818-269-4091  
Fax: 818 904 3327 info@emcod.com techsupport@emcod.com